



PolyWorks[®]

v12

PolyWorks | Inspector[™] Airfoil Gauge Module

The most comprehensive airfoil inspection solution on the market for a complete dimensional analysis of fan, compressor, and turbine blades

Complete solution for quality control

- Use the most powerful and robust camber line fitter in the industry (handles all standard cambered blades as well as blades with non-cambered thick sections and blades with one or two cutback ends)
- Process datasets produced by any 3D measurement principle (white and blue light digitizers, X-ray digitizers, lasers scanners, CMMs)
- Benefit from all the standard functionality of PolyWorks/Inspector (parametric, traceable, and updatable inspection projects, comprehensive set of part and cross-sectional alignment methods, cylindrical and conical sectioning and unfolding, statistical process control and trend analysis, and more)

Most flexible toolbox for adaptive modeling and manufacturing

- Digitize a set of legacy or competitor blades, build an average blade model, and analyze the upper and lower tolerance envelopes of the multi-piece set
- Use airfoil gauges and extract key features and dimensions on a damaged blade to create a local repair model in your corporate CAD modeler
- Benefit from all the standard functionality of the optional PolyWorks/Modeler[™] package (NURBS surfacing, 2D sketching, NURBS curve creation and editing)



RP +X 2
Dist along X: -0.000

RL +Y 1
Dist along Y: -0.000

RP +X 1
Dist along X: 0.000

RP +X 3
Dist along X: -0.000

RP -Z
Dist along Z: 0.000

RL +Y 2
Dist along Y: -0.000

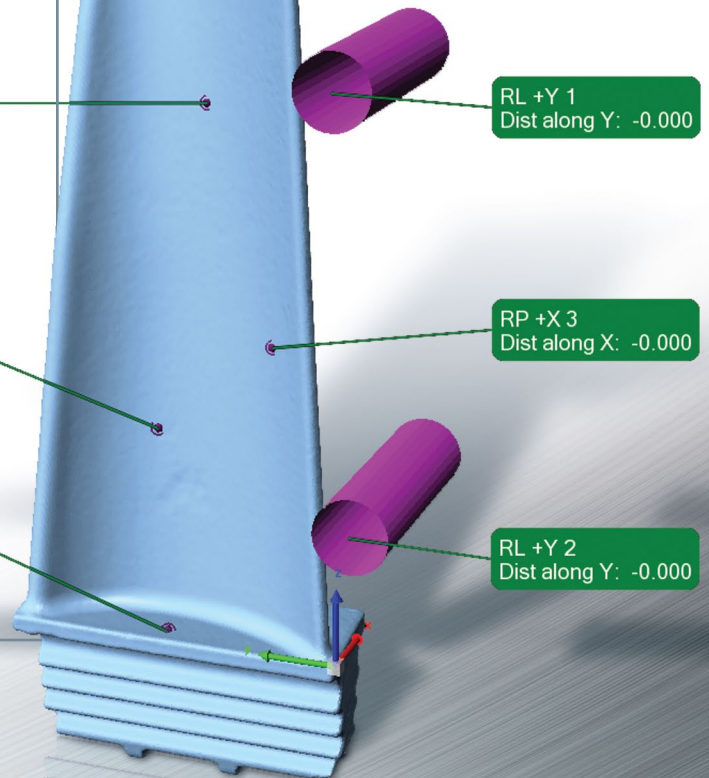



Technical Specifications

Standard Dimensional Measurements

- Leading and trailing edge radii
- Camber line length
- Maximum thickness
- Chord length
- Maximum width (aerodynamic and tangential)
- Twist and stagger angles
- Smallest enclosing circle
- Inlet and exit angles
- Unlimited number of thickness measurements along the camber line from leading edge or trailing edge points (10 by default)
- Area
- Distance between airfoils in a ring or blisk

Geometric Primitives

- Camber line
- Leading edge point
- Trailing edge point
- Center of gravity
- Maximum thickness point
- Smallest enclosing circle
- Tangent vector
- Leading edge tangent point
- Trailing edge tangent point

Data-to-CAD Point Deviations

- Leading edge point deviation
- Trailing edge point deviation
- Center of gravity deviation
- Maximum thickness point deviation
- Leading edge tangent point deviation
- Trailing edge tangent point deviation

PolyWorks airfoil gauges are fully customizable and can be reprogrammed to meet specific customer requests

